

Vehicle: All Technical Service Bulletins

Engine Overheats, Install Cooling Fan Relay Kit

File In Section: 6 - Engine

Bulletin No: 53-62-04

Date: November, 1995

Subject:
Engine Overheats (Install Cooling Fan Relay Kit)

Models:
1994-96 Chevrolet Caprice with SEO Option

Condition

Some owners may comment that the engine overheats. This condition occurs only in heavy duty operation, such as police or taxi use.

Cause

The primary 150 watt cooling fan relay may overheat and tail, making the cooling fan inoperative and resulting in the overheat condition. The secondary fan may operate, but will not provide enough cooling air by itself to prevent overheating.

Correction

To correct this condition, the relay will be moved to a new location and the terminals will be upgraded. A kit, P/N 12167644, contains the parts needed for this procedure.

1. Disconnect negative battery cable.
2. Locate the underhood electrical center and remove the cover. The electrical center is at the top rear of the right front wheel house.

Figure 1

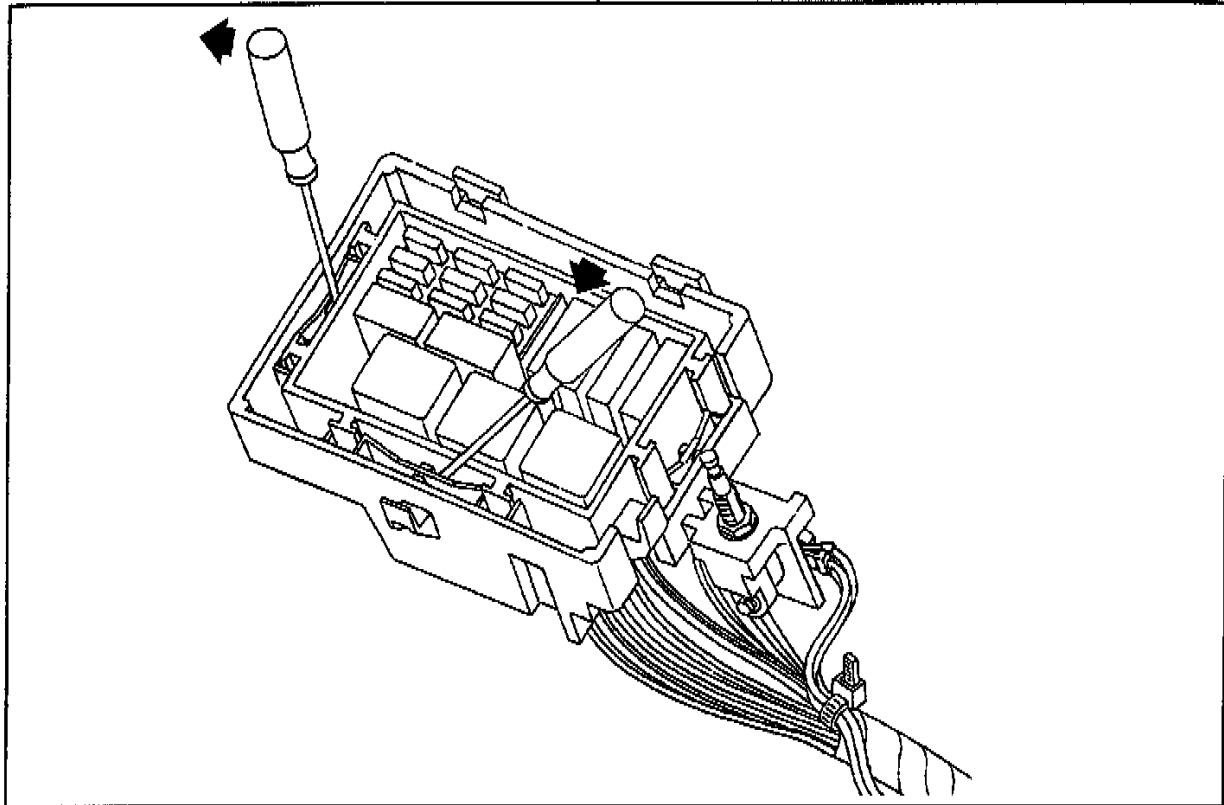

3. Remove the electrical center from the casing (Figure 1). Release the tabs using a small screwdriver, as shown.

Figure 2

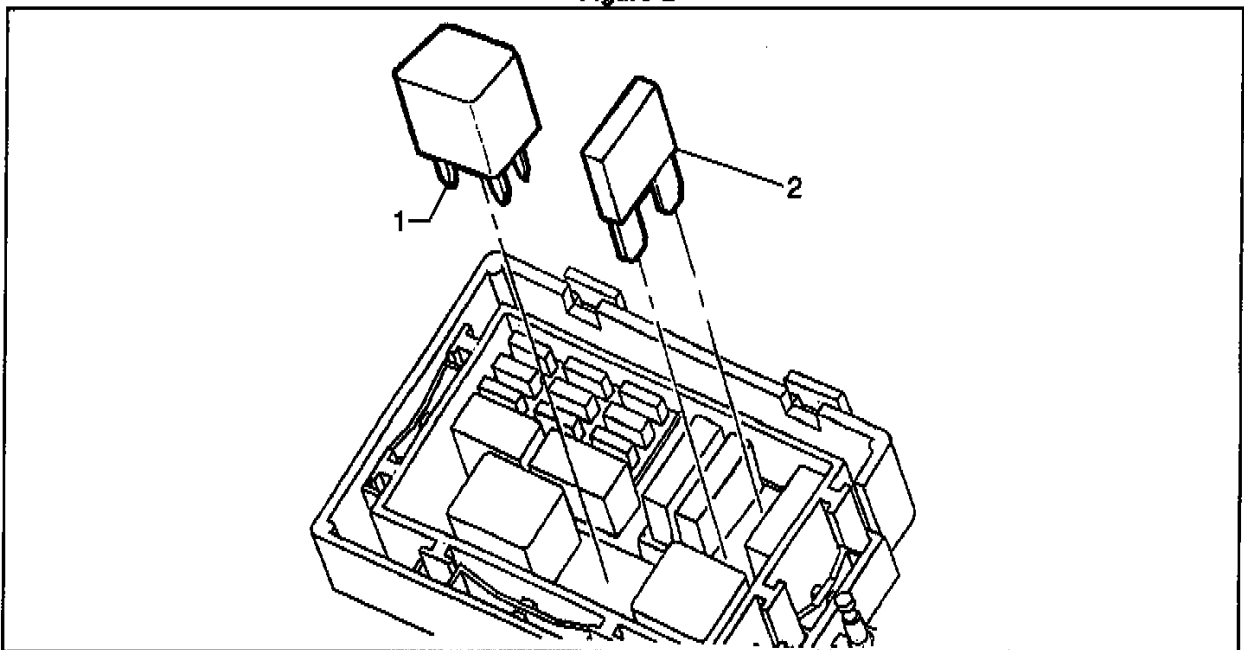

Legend

- 1. Cooling Fan Relay.
- 2. 40 Amp Maxi-fuse.

- 4. Remove the primary cooling fan relay and the 40 amp # 12 Max-fuse (Figure 2).

Figure 3

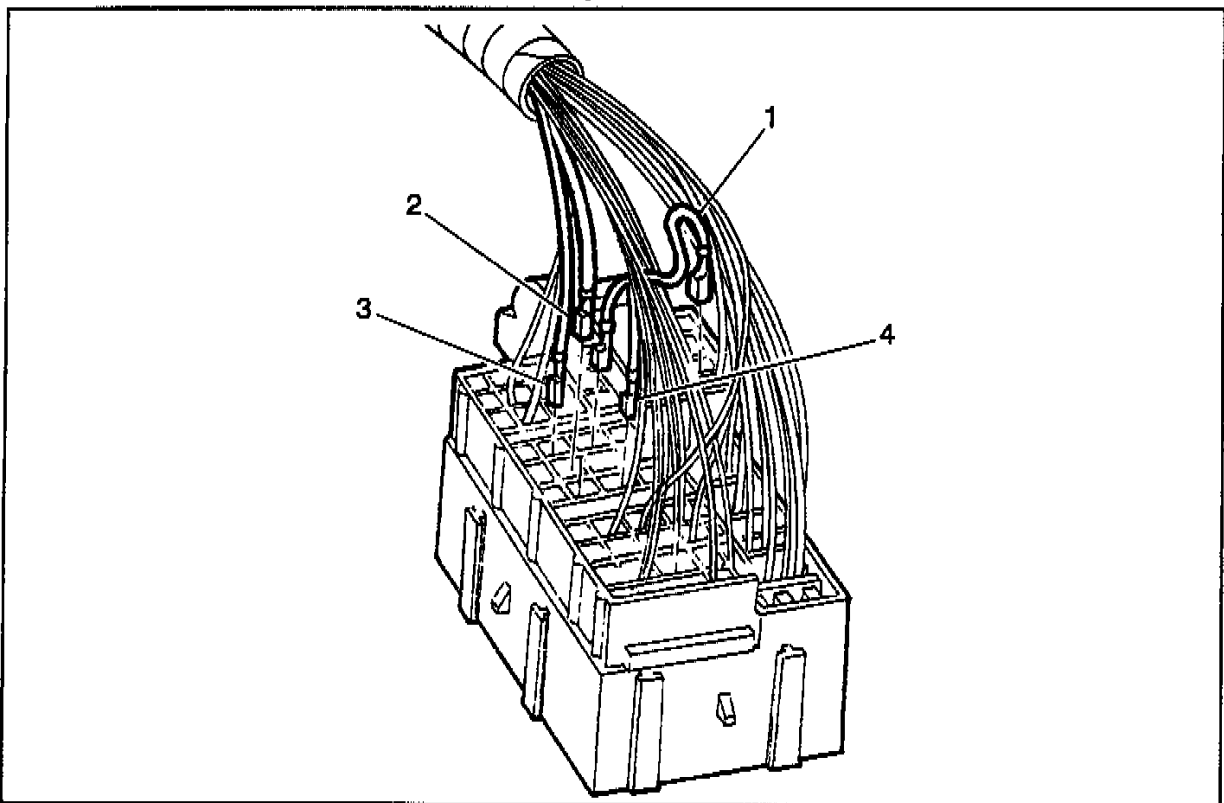

Legend

- 1. Red Jumper Wire - K2 & C4.
- 2. Blue Wire B6.
- 3. Brown Wire B4.
- 4. Green Wire C6.

- 5. From the back of the electrical center (Figure 3):

- a. Remove the red 10 gauge (5.0) jumper wire and terminals from cavities K2 and C4. Discard this wire.
- b. Remove the blue 10 gauge (5.0) wire and terminal from cavity B6. Cut off the terminal and discard. Tape the wire end.
- c. Remove the brown 22 gauge (.35) wire and terminal from cavity B4 and the green 22 gauge (.35) wire and terminal from cavity C6. These wires will be used in Step 7.

Figure 4

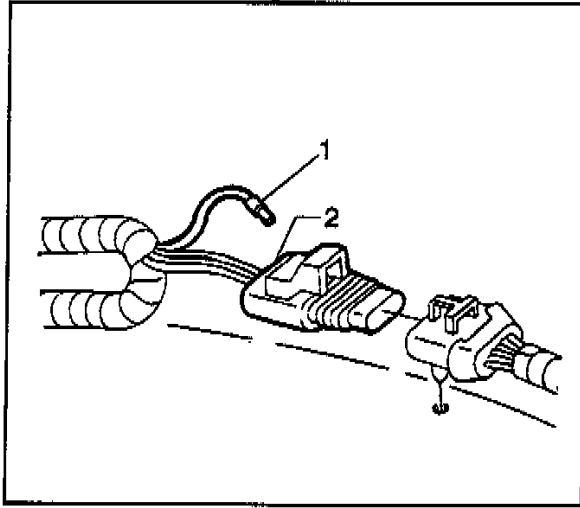

Legend

- 1. Blue Wire.
- 2. Cavity "A".

- 6. Locate connector C103, just in front of the electrical center (Figure 4). Unplug the connector, then remove the blue 10 gauge (5.0) wire and terminal from cavity A. Cut off the terminal and discard, and tape the bare end of the wire.

Figure 5

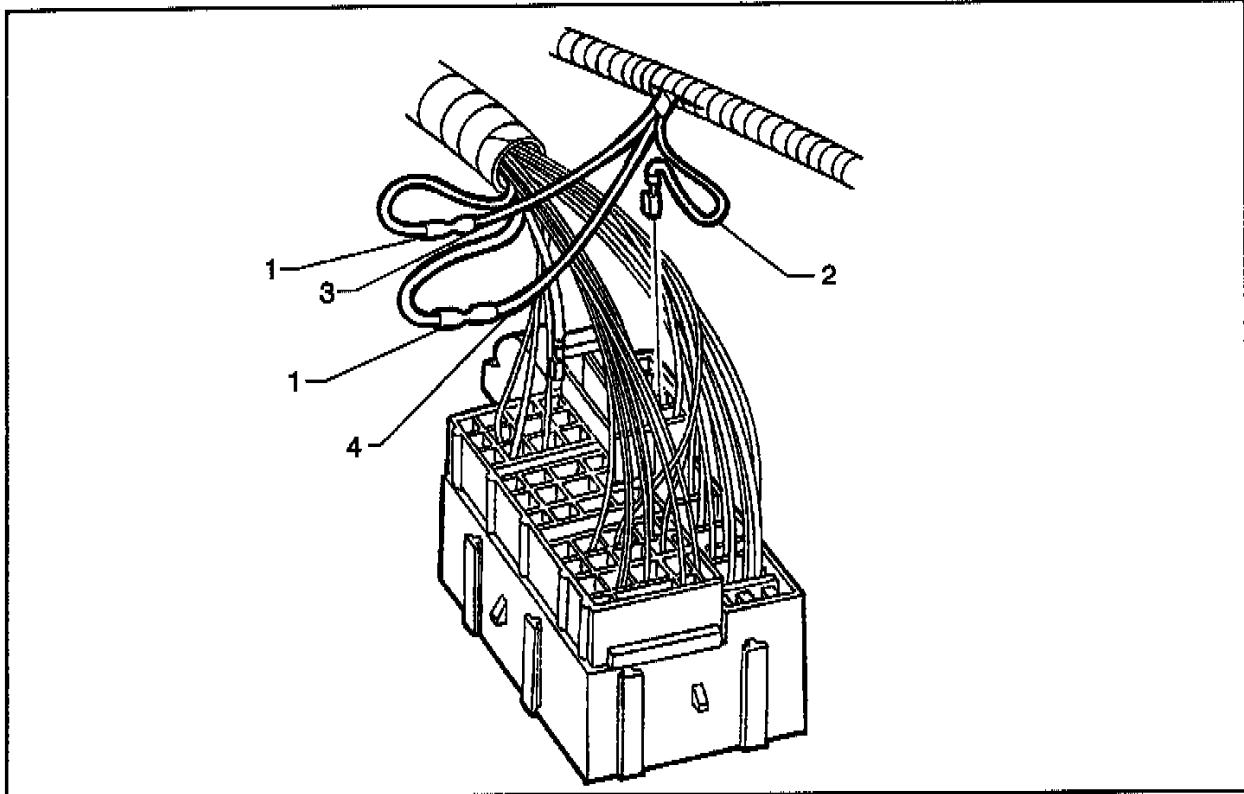

Legend

- 1. Crimp and Seal Connectors.
- 2. Red Wire to K2.
- 3. Brown Wire.
- 4. Green Wire.

7. Locate the new jumper harness from the kit. Insert the red wire and terminal into cavity K2 of the electrical center (Figure 5). Cut the old terminals from the brown and green wires removed from the electrical center in Step 5, and discard. Strip the ends of the wires. Crimp the ends of the wires into the connectors on the brown and green wires in the new jumper harness. Heat shrink the connections to insure a water tight seal. Reinstall the electrical center into the case.
8. Reinstall the 40 amp Maxi-fuse.

Figure 6

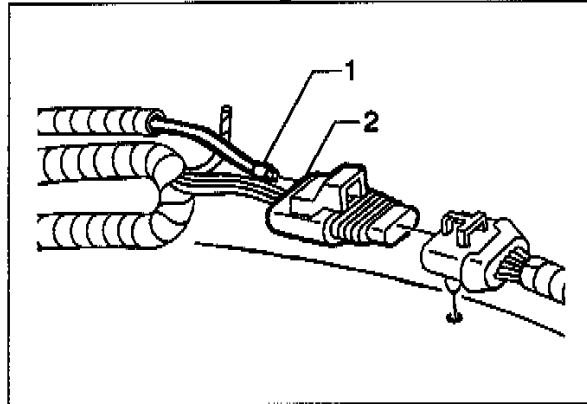

Legend

1. Blue Wire.
2. Cavity "A".

9. At connector C103, install the blue wire and terminal from the new jumper harness into cavity A (Figure 6). Plug the connector together.

Figure 7

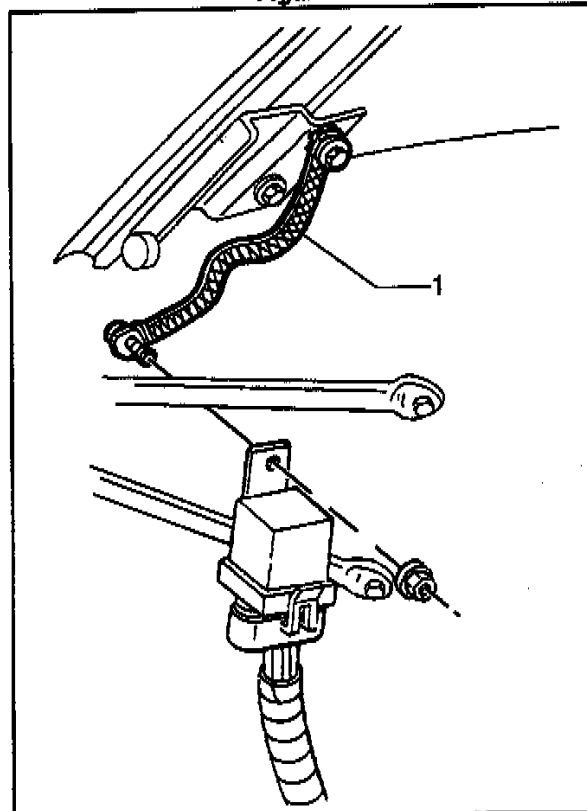

Legend

1. Ground Strap.

10. Remove the hex nut which secures the hood ground strap to the cowl (Figure 7). Install the relay from the new jumper harness in this location. Leave the ground strap in position.
11. Secure the jumper harness into position, making sure there are no rub or pinch points.
12. Reconnect the negative battery cable. Verify the operation of the cooling fan using the Tech 1 (see Service Manual for details).

Parts Information

Parts are expected to be available on November 20, 1995.

Warranty Information

For vehicles repaired under warranty, use:

Labor Operation	Labor Time
N6270	Use published labor operation time.